

# Busdisplay

## Information and Assembly Guide



**Sleepy Pony Labs**

[www.sleepyponylabs.com](http://www.sleepyponylabs.com)

Document Revision **1** for Board Revision **1**

For the latest updates, visit us at  
<https://www.sleepyponylabs.com/>

# Introduction

Welcome and thank you for purchasing the Busdisplay soldering kit from Sleepy Pony Labs! The Busdisplay is a small PCB that allows you to monitor the current data on an 8-bit bus. The data is shown on a 7-segment display. Both decimal mode (0-255) and hexadecimal mode (0x00-0xFF) are supported and could be set by a jumper.

This kit is useful for debugging your project, for example, showing current data on your retro computer bus. However, this is not a replacement for a logic analyzer and does not have that high bandwidth. You should verify that this board is suitable for your needs first!

## Specifications

- **PCB board:** Black FR4 board of size 35\*53 mm
- **Parts count:** 19 pieces
- **Power supply:** 5v via pin header
  
- **Soldering Difficulty:** 6/10
- **Soldering Type:** Through-hole and SMD. Smallest pitch 0.65 mm.
  
- **Firmware parts:** PIC16F57 x1

**Note:** Unfortunately, due to some bad design decisions, the ICSP header does not work in this revision unless you removed the buffer IC. Sorry! 😞

## Unpacking List / Bill of Materials (BOM)

References	Description	Footprint	Quantity
C1, C2	100nF Ceramic Capacitor	0603	2
C3, C4	15pF Ceramic Capacitor	0603	2
R1	10 k $\Omega$ Resistor	0603	1
RN1, RN2	470 $\Omega$ Resistor Array	0603x4	2
RN3	10 k $\Omega$ Resistor Array	0603x4	1
Q1 – Q3	AO3401 P-Ch MOSFET	SOT-23	3
LED1	SP410401N 7-Segment Display	THT	1
U1	PIC16F57-I/SO Microcontroller	SOIC-28	1
U2	74HCT244 Buffer IC	TSSOP-20	1
X1	4 MHz Crystal	HC-49	1
H2	8-Pin Male Header	THT	1
H3	2-Pin Male Header	THT	1
H4	3-Pin Male Header	THT	1
-	Jumper	THT	1
		<b>Total</b>	<b>19</b>

**Note:** ICSP header not included.

**Note:** High resolution image of the PCB is on page 12.

**Note:** An Interactive BOM is not available for this board.

# Assembly Guide

**The general guide in soldering anything is to solder components with the lowest profile (least in height) first before soldering other taller components.**

**This guide sums up my experience in soldering the board during the testing. Follow the steps here to reduce possible problems.**

**Note:** Before we proceed, since this kit contains SMD parts, I would like to give some recommendations first.

- Be careful while unpacking. Remove parts from their tubes/tapes ONLY when you need it and be careful while doing so. SMD parts are very hard to identify and easy to lose after they leave their packaging.
- Conical tip that comes with most soldering iron will not work well with SMD (or anything really). I recommended you get a horse hoof tip (Hakko type C) or a chisel tip (Hakko type D) because these will transfer heat better and allow you to perform neat tricks such as drag soldering.
- Make sure you have all the tools needed. At the minimum, I suggest you have a temperature-controlled soldering-iron, a tweezer, good brand of solder, flux, and solder wick. Do NOT use eBay junk please.
- SMD pads are small and easier to break than through-hole counterparts. Use temperature between 350-400 Deg Celsius while soldering and do not hold your iron on the pads too long because that is how you lift them off. If the solder bridge between pads, a lot of flux and solder wick helps. You might find a soldering pump easier for you, but from my own experience it has a higher chance of damaging the board.
- While tacking one side down first then solder the other side is a standard practice for parts with two pads, you might find putting a part on the board, applying flux, then use already melted solder on your iron to tack both sides in one go easier. Try and see which way works best for you.
- **Do not afraid to try. We all start somewhere.**

## 1. IC

Since there are passive components around the ICs, we will need to solder the ICs first (more clearance for the iron).

Align the chip with the pads. The Pin-1 Mark on the chip should match the dot on the board. Hold the chip with tape then solder diagonal pins first so it will not move around (for example, pin 14 and 28, or pin 1 and 15). Then solder the rest of the pins.

U2 is harder to solder than U1 because it has a smaller pitch of 0.65 mm. You might want to check out TSSOP soldering tutorial online first. For example: <https://youtu.be/-I5D2em4PBI> from Androkavo.

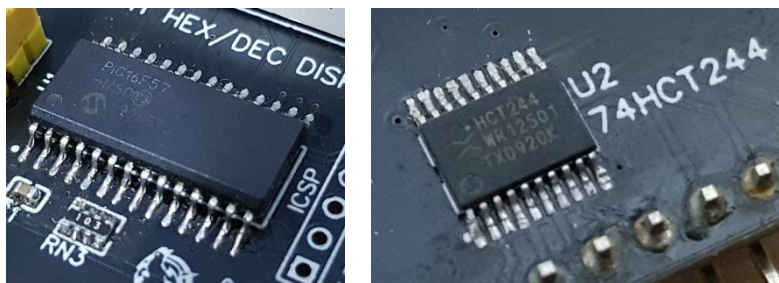

## 2. Resistors

Remove the parts from its packaging onto the board. Flip them so that the side with numbers is up. First, put small amount of solder on one pad, then use your tweezers to hold the resistor to the pad. Heat the pad up again until the solder flows to the resistor. Finally, solder the remaining pad.

**Note:** You can touch up with an iron and flux if you have cold joints.



### 3. Capacitors

Remove the parts from its packaging onto the board. Flip them so that they lay flat to the board. First, put small amount of solder on one pad, then use your tweezers to hold the resistor to the pad. Heat the pad up again until the solder flows to the capacitor. Finally, solder the remaining pad.

**Note:** You can touch up with an iron and flux if you have cold joints.

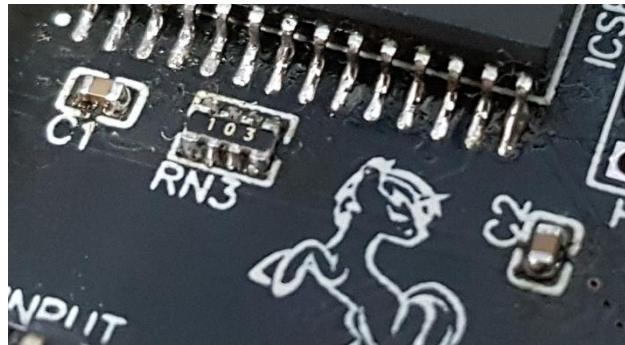

### 4. Resistor Array (HARD)

Remove the parts from its packaging onto the board. Flip them so that the side with numbers is up. First, put small amount of solder on one corner pad, then use your tweezers to hold the resistor to the pad. Solder that pin and its diagonal pin first so it will not move around. Then solder all remaining pads.

It is very likely that solder bridges will form on these resistor arrays. Just put a lot of flux on the bridge, clean your iron tip, then use it to wipe the legs outward. Any excess solder will be sucked out. Androkavo also made a tutorial video for this: <https://youtu.be/omR7QE8H82w>

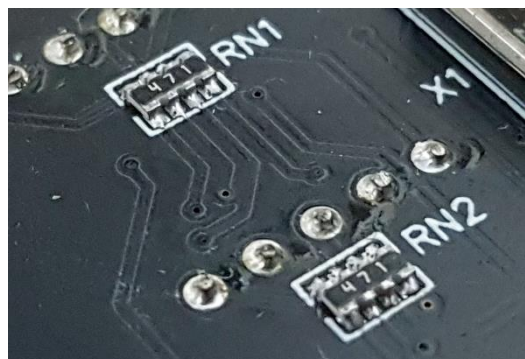

## 5. MOSFET

Remove the parts from its packaging onto the board. Flip them so that the right side is up. Solder one pin first to hold the FET in place, then solder the rest of the pins.

Pay extra attention to make sure these MOSFETs are soldered correctly. It would be very hard to fix any problem after we soldered the display on top.

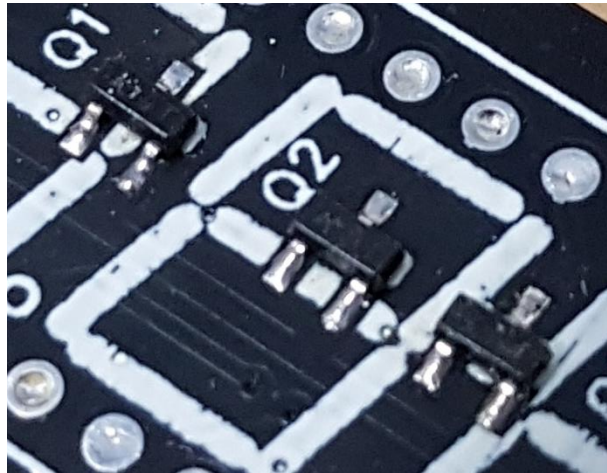

## 6. Crystal

First, put small amount of solder on one pad, then use your tweezers to hold the crystal to the pad. Heat the pad up again until the solder flows to the leg. Finally, solder the remaining pad.

**Note:** Crystals are sensitive to shock. Be careful not to drop it.



## 7. 7-Segment Display

Insert the display fully through the hole. Hold it with tape and solder it. Finally, remove the protective sticker.

**Note:** If you plan to clean the board with flux cleaner or alcohol later, leave the protective sticker intact for now and only remove it after you are done. **Cleaning solutions will dissolve the black display coating.**



## 8. Pin headers

Insert the pin header fully through the hole. Hold it with tape and solder it. Longer side should be facing up.

- For angled pin header H2, make sure to put the shorter side into the hole.
- For pin header H4, put the jumper onto it after soldering.
- **Note:** In the picture H3 was substituted with a female header which you can also do, but only male header will be supplied in the kit.

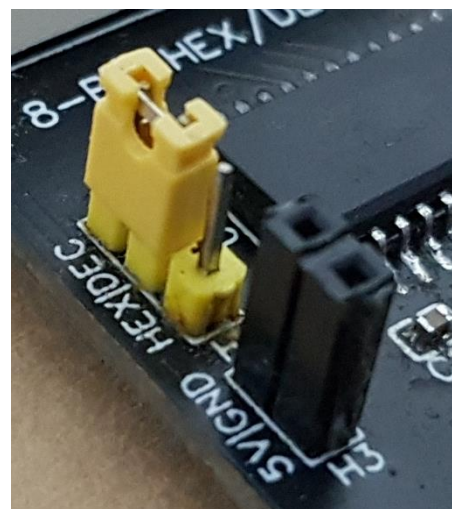
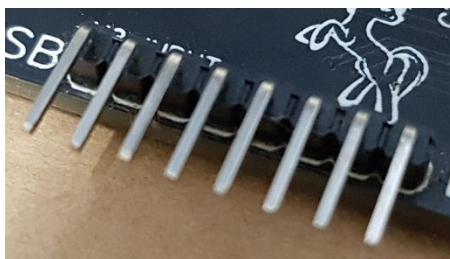



## How to Use

After all the parts were soldered, connect a 5v power to pin header H3. The display should light up. If you have not connected anything to input header yet, the display might be erratic. This is normal.

Try connecting the input signals to 5v and ground. Verify that the display shows the correct data.

Try switching the Hex/Dec jumper. The display should show correct data in both formats. The board will not work correctly if the jumper is missing.

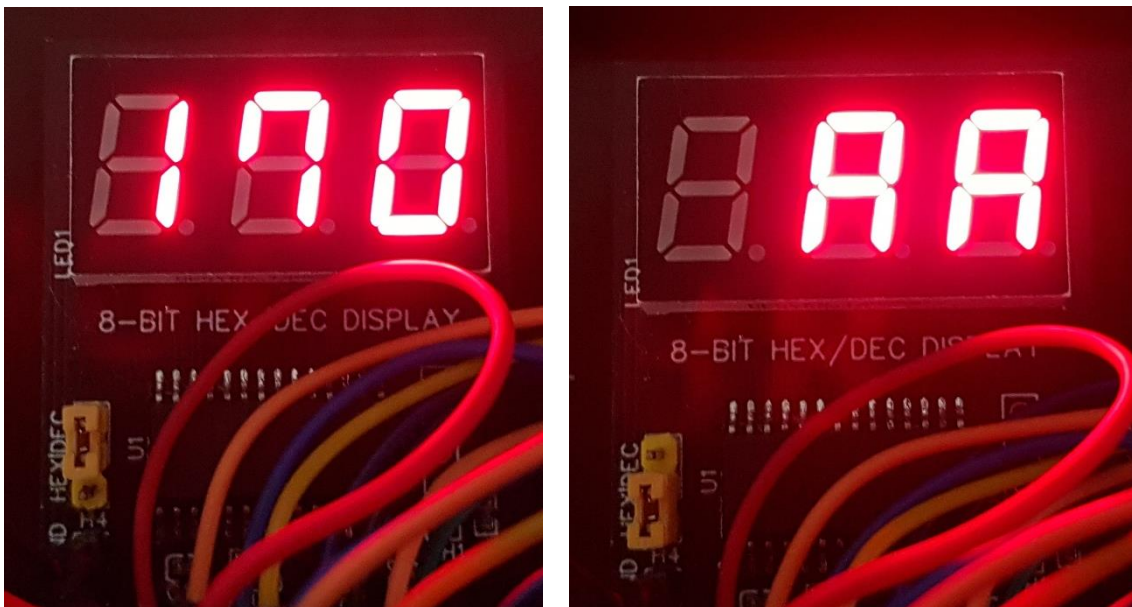

**Input is 10101010, display shows 170 (Dec) and AA (Hex) [Correct]**

# Troubleshooting

In case your circuit does not work, the list below contains some possible causes of the issue from most likely to least likely:

- Bad solder joints (Cold joints, Short between joints, Unconnected joints)
- Incorrectly installed components (Wrong location or orientation)
- Bad power supply (Battery dry, Wrong type, Wrong polarity)
- Components damaged by soldering heat.
- Components damaged by static electricity or broken from the factory.
- PCB damaged by soldering heat or impact (Broken pads or traces).

And these are possible causes specific to this kit:

- If the board does not work at all (no display at all or the display does not update) the most likely cause is the crystal circuit. A pair of 15nF loading capacitors is what recommended in the datasheet and are what supplied in the kit. But if that does not work for you, you might try replacing it with other values. Please refer to section 4 of PIC16F57 MCU datasheet here: <https://ww1.microchip.com/downloads/en/DeviceDoc/41213D.pdf>
- If the display signal bleeds off to another segment or missing entirely, the most likely cause is one or more bridges and/or cold joints at the resistor networks. Check them closely or try reheating them up with flux again to make sure everything is correctly soldered.

# Schematics

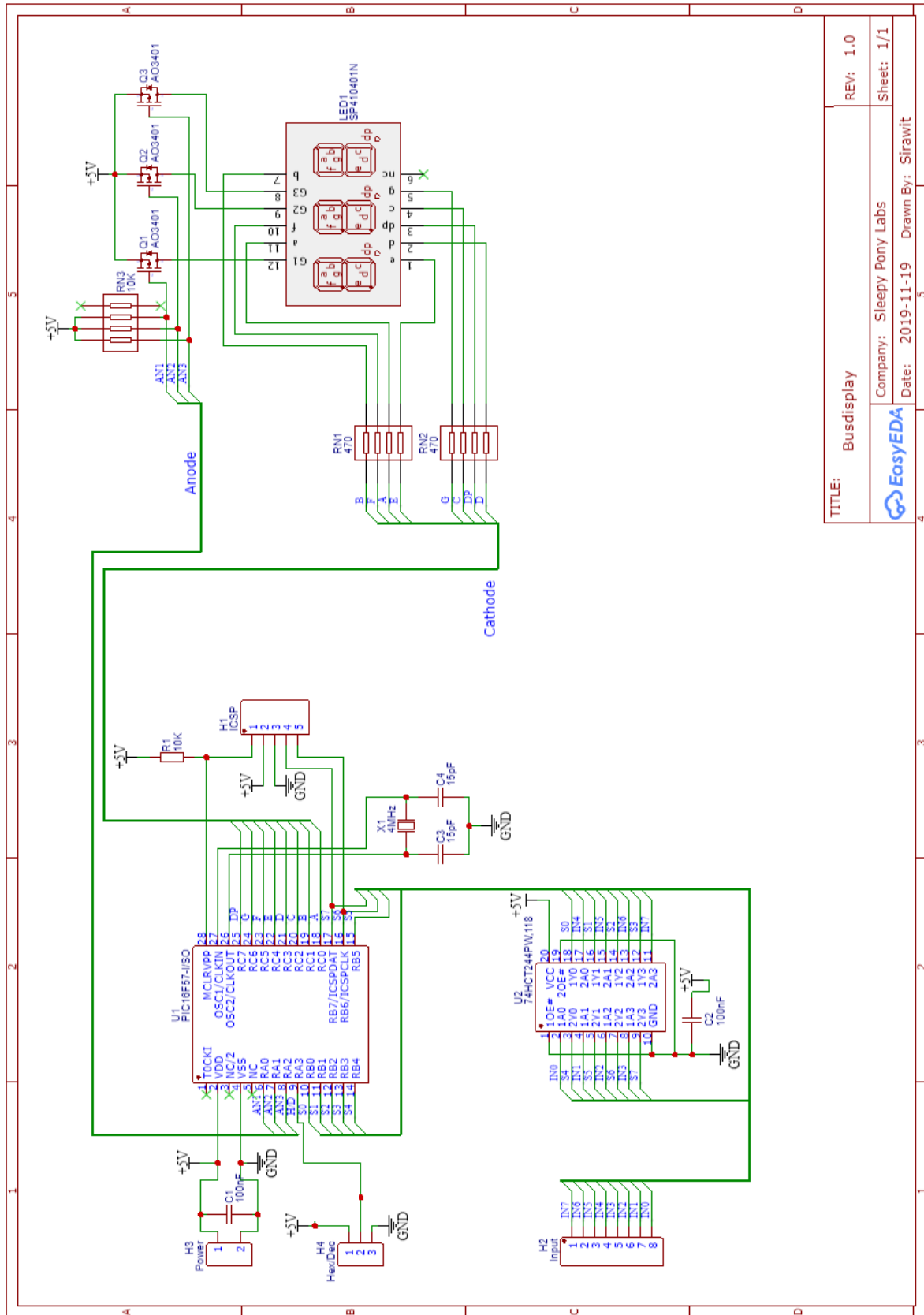

TITLE:	Busdisplay	REV:	1.0
Company: Sleepy Pony Labs		Sheet: 1/1	
Date: 2019-11-19		Drawn By: Sirawit	

# PCB Layout

## Front

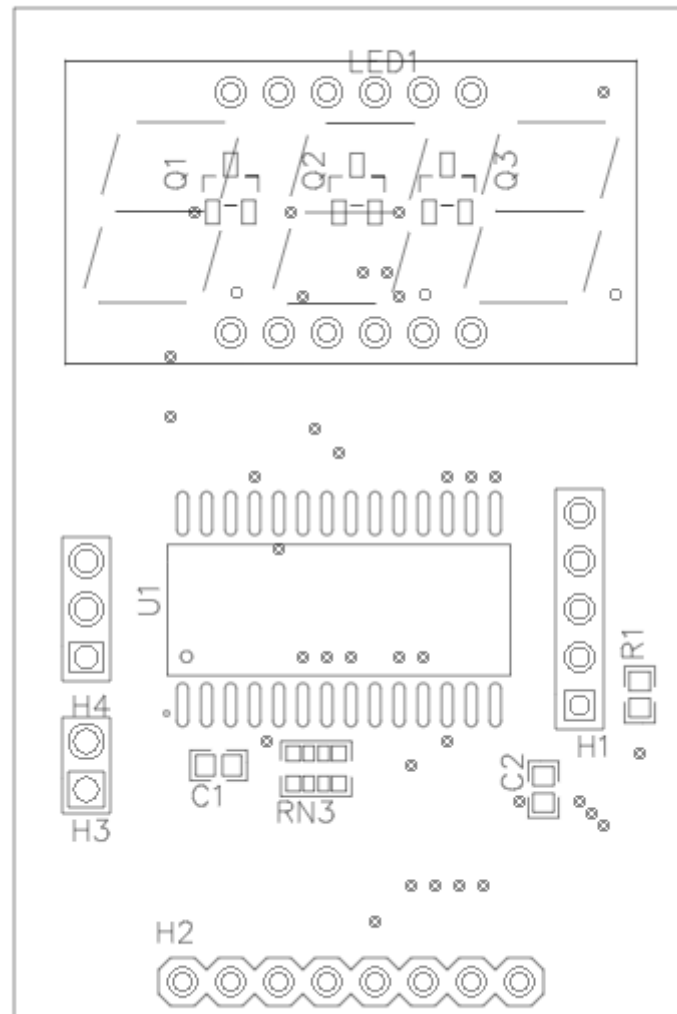

# PCB Layout

## Back

